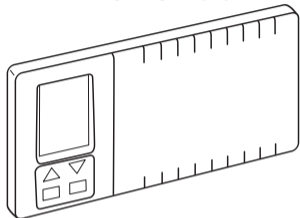

AURATON 2020

AURATON 2020

AURATON 2020 TX RX Plus

Preliminary notes

The manual includes the information on **AURATON 2020** and **AURATON 2020 TX RX Plus** controllers.

Operation of both the controllers is identical; therefore the whole information is placed in a single chapter. The information related to their installation is placed in separate sections of the manual.

AURATON 2020 TX Plus enables independent modification of the protection code of the **RX** receiver communication.

The controller is programmed in the factory to 085 code number. Nevertheless, if any communication problem arises or another wireless temperature controller set operates in the neighbourhood, the code should be changed in accordance with the instruction at page 51.

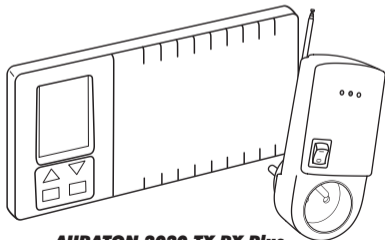
**AURATON 2020 TX RX Plus**

1. Installation of **AURATON 2020**

Note: During installation of the controller the power supply should be switched off. It is recommended to charge a specialist company with the installation.

1.1 A choice of proper location of the **AURATON 2020** controller

Appropriate operation of the controller strongly depends on its location. The location without air circulation or in a directly insulated place results in inappropriate control of temperature.

In order to ensure proper operation of the controller place it on an internal wall of the building (between the rooms).

A place of usual sojourn should be chosen, with free air circulation.

Avoid the places in the proximity of heat emitting equipment (TV set, heater, refrigerator) or subject to direct insolation. Do not locate the controller in a place adjacent to the door, in order to avoid its vibration.

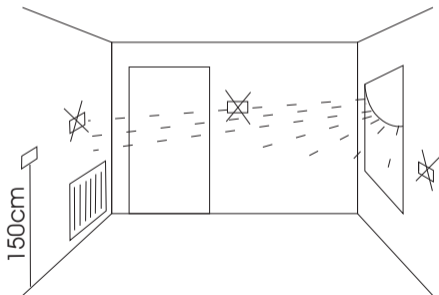

proper location of the controller

1.2 Conductor terminals of **AURATON 2020**

The conductor terminals may be accessed after removing the cover of the front controller panel, batteries, and 2 screws fixing the protection plate. There are three terminals, marked by COM, NO, and NC. This is a typical unipole two-state relay.

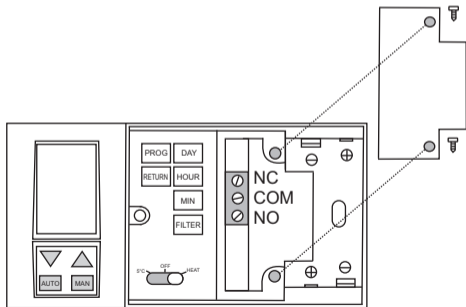

1.3 Assembly of the **AURATON 2020** controller

The controller is assembled with the help of a pattern. Bore two holes of the diameter of 6mm in the wall. Drive the bolts and tighten the controller with screws, the left-hand screw longer than the right-hand one.

Note: In case of installation of a controller provided with a floor sensor pay attention to Figure inserted in Section 18.3, page 24.

Note: In case of a wooden wall the pins should not be used. Drill the holes of 2.7mm instead of 6mm diameter and fasten the screws directly to the wood.

2. Acquaintance with the **AURATON 2020** **AURATON 2020 TX Plus**

2.1 Outer view

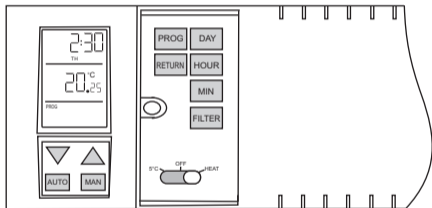

The **AURATON 2020** and **AURATON 2020 TX Plus** are programmable controllers. They are able to adjust the room temperature to the desired level 4 times within 24 hours, from Monday to Friday, and twice within 24 hours on Saturdays and Sundays.

This enables very accurate defining the temperature cycle within the working week, when activity of inmates is increased, and in weekends, during a rest time.

It allows for programming with one-minute accuracy. At the front panel of the controller a slidable cover is located. When open, it gives access to the following pushbuttons:

- the time programming pushbuttons:
DAY, HOUR, MIN;
- the button of operation time of a heating system
FILTER;
- temperature programming pushbuttons:
PROG, RETURN;
- the positioning switch
5°C - maintaining the antifreeze temperature;
OFF - heating device breaker;
HEAT - automatic operation (heating).

At the left-hand side there are

- two triangular buttons for temperature setting
▼ ▲ ;
- two pushbuttons:
AUTO (automatic control),
MAN (manual control) alternating the controller operation mode between automatic or manual;
- a large multi-function display LCD.

The cover may be removed in order to exchange the batteries. Once it is removed the access to 2 R-6 batteries is opened.

2.2 Display

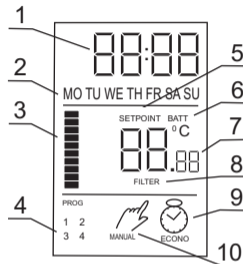

1. The time is displayed in 24-hours system.
2. English abbreviations of the days of the week indicate the current day.
3. A bar indicating switching on the heating device.
4. The digits indicate the currently operating program.

5. Is the **SETPPOINT** indication displayed, the temperature indicator '7' shows the programmed temperature instead of the room temperature.
6. Low battery indicator reminds the need of exchanging the batteries for new ones. The batteries should be then replaced as soon as possible.
7. Temperature. In normal operation mode the controller displays temperature of the room where it is installed.
8. Indicator of operating hours of the heating device.
9. The indicator of energy-saving operation mode appears (always together with the manual control indicator) when the program operation is temporarily suspended in order to set any energy-saving temperature level for a predetermined period of time (from 1 to 7 days, with one-minute accuracy).
10. The manual control indicator appears when program operation is cancelled and manually adjusted temperature is to be maintained permanently.

3. Putting the controller into operation

Once the batteries are installed, the controller starts operation with its default parameters. It means that the following information will be displayed:

Time: 00:00 (midnight)

Day: MO (Monday)

Temperature indicator: current room temperature

Program: 2 (initiated on Sunday and lasting until 6:00 a.m. on Monday).

Temperature settings:

PROG1: from 6:00 a.m. 21°C

PROG2: from 8:30 a.m. 21°C

PROG3: from 4:00 p.m. 21°C

PROG4: from 11:00 p.m. 17°C



It means that from 6:00 a.m. to 8:29 am the temperature is adjusted to 21°C, from 8:30 a.m. to 3:59 pm the temperature is adjusted to 21°C, from 4:00 p.m. to 10:59 pm the temperature is adjusted to 21°C, and from 11:00 p.m. to 5:59 am the temperature is adjusted to 17°C.

This may be graphically presented as follows:

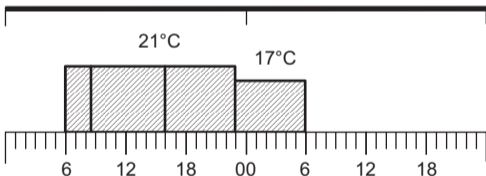

These setting may be changed

4. Setting the controller

AURATON 2020

AURATON 2020 TX Plus

4.1 Adjustment of the day of the week (No 2 at the display)

1. Move the battery cover to the right.
2. Repeat pressing the **DAY** pushbutton until proper day of the week appears at the display, according to the point 2.2.

4.2 Setting the clock (No 1 at the display)

1. Move the battery cover to the right.
2. Repeat pressing the **HOUR** pushbutton until proper hour appears at the display.
3. Repeat pressing the **MIN** pushbutton until proper minute appears at the display.

4. Slide the battery cover back to its place. Now the controller clock indicates proper date and time.

Note: Longer pressing the **DAY**, **HOUR**, or **MIN** pushbutton (exceeding 2 seconds) causes automatic scrolling of the day, hour, or minute value, respectively.

4.3. Description of the programming function

AURATON 2020 and **AURATON 2020 TX RX Plus** remember 8 temperatures that may be adjusted in the range from 5°C to 27°C with the accuracy of 0.5°C.

The antifreeze temperature is constant and may be adjusted by the slider (accessible after uncovering the batteries).

The controller enables adjusting 4 temperature values for one 24-hours period that will be in force equally for 5 working days of the week, from Monday (MO) to Friday (FR). Additionally, the controller allows to set separately 2 temperatures for Saturday (SA) and Sunday (SU).

In order to program the controller efficiently you should decide what temperatures would be required at home (in the office) from Monday to Friday, and on Saturday and Sunday, and at what time should they change. A simple table, proposed here, would be helpful for this purpose.

For the period from Monday to Friday:

Program No	Hour	Temperature adjustment
program 1		
program 2		
program 3		
program 4		

For Saturday (SO):

Program No	Hour	Temperature adjustment
program 1		
program 2		

For Sunday (SU):

Program No	Hour	Temperature adjustment
program 1		
program 2		

4.4 Programming at the first start after installing the batteries

1. Move the battery cover to the right and the slider move to **HEAT**.
2. Press the **PROG** button, the display will be as follows:
The indicator of the Program 1 blinks, which means that it is to be set.
3. Repeat pressing the buttons **HOUR** or **MIN** (no later than 10 seconds after **PROG**) with a view to adjust the time of setting the temperature.



4. Press the buttons ∇ \triangle (no later than 10 seconds after setting the hour and minutes) in order to adjust the temperature that the controller should maintain since the previously set time. The temperature may be adjusted in the range from 5°C to 27°C with the accuracy of 0.5°C.



5. Press **PROG** again (no later than 10 seconds after the previous operation). The display will be as follows: The indicator of the Program 2 blinks, which means that it is to be set.

6. Proceed according to the points 3 and 4, in order to set the time of switching to the required temperature.

7. Press **PROG** (no later than 10 seconds after the previous operation). The display will be as follows:



8. Proceed according to the points 3 and 4.
9. Press **PROG**. The display will be as follows:
The program indicator blinks. The program 4 is to be set.



10. Proceed according to the points 3 and 4. This way are set up 4 temperature thresholds and four time moments of the day in which the temperature should be changed, from Monday (MO) to Friday (FR).

11. Further PROG pressing (no later than 10 seconds after the previous operation) switches the procedure to programming two temperature ranges for Saturday (SA) and Sunday (SU), separately. The display will be as follows:
The indicator of the Program 1 blinks, like in the point 2, but the day indicator shows Saturday (SA).

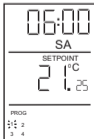

12. Proceed according to the points 3 and 4.

13. Press **PROG**. The display will be as follows: the indicator of the Program 2 blinks, enabling setting the second, i.e. the last program for Saturday (SA).



14. Proceed according to the points 3 and 4

15. Proceed according to the points 11 to 14 in order to set the program for Sunday (SU).

16. Press **RETURN** or wait 10 seconds until the controller records the changes in its memory and resumes automatic operation.

Thus, the whole temperature cycle is programmed, including 4 settings for 5 working days and 2 separate settings for Saturday and Sunday. The Table previously drawn up could be helpful in efficient operation.

4.5 Advanced programming.

A)

During normal operation of the controller pressing the **PROG** button (as opposed to the first start after installation of the batteries) leads to quite different state of the display, as opposed to the point 6. (consistent with the one previously set).

Any program may be modified, irrespective of the other ones. Any time the **PROG** button is pressed, in the intervals shorter than 10 seconds, the next program is selected for modification.

Example 1

The **PROG** button pressed 3 times enables modification of the Program No 3, in force from Monday (MO) to Friday (FR).

Example 2

The **PROG** button pressed 5 times enables modification of the first program in force for Saturday.

Example 3

The **PROG** button pressed 9 times returns the operation to the first program for working days.

In order to avoid a mistake observe the indicators '2' and '4' according to the display description in the point 5.2. The programming is completed by pressing **RETURN** or waiting 10 seconds without pressing any key.

B)

It is possible to program all 8 temperatures to the same value, e.g. 21°C. In such a case the equal temperature is maintained the whole week through, irrespective of the hours of theoretical switching between the temperatures (no need to change the switching time while programming).

C)

Programming sequence described in the point 7.3 may be changed, i.e. the temperature may be programmed at first and, afterwards, the time.



D)

Programming of some or all four programs for 5 working days, or for Saturday or Sunday, is also possible with the same hours and different temperatures. In such a case the controller shall maintain the temperature corresponding to a program of lower number.

NOTE: The Program 2 of Sunday lasts until 6:00 a.m. on Monday. The Program 4 of Friday lasts until 6:00 a.m. on Saturday (this is valid for factory settings made prior to the changes imposed by the User).

5. Manual operation

Short pressing the **MAN** button causes that the controller ceases execution of the program and resumes manual operation. The symbol "  " appears on the display.

Required temperature, to be maintained the whole week through, may be adjusted with the help of the buttons "   ". Automatic operation is resumed again by pressing AUTO.

6. Energy-saving operation

This mode enables temporary setting of any temperature for the period up to seven days with the accuracy of 1 minute. Afterwards, the controller returns to the automatic operation program. When we leave home for 3 days, the room temperature may be reduced but a certain time before our return the automatic operation should be resumed.

In result, returning home we should not even remark that the temperature was reduced during our absence. We could only remark that the energy expenses are lower.

Example

We intend to leave on Wednesday at 9:31 a.m., planning to return on Sunday at about 8:00 p.m. The energy necessary for heating may be saved during our absence.

1. Press the **MAN** button for about 3 seconds, until two symbols   appear together at the display.

2. Set the temperature to be maintained during our absence, e.g. 17°C, using the appropriate buttons.
3. Pressing the buttons **DAY HOUR MIN** (in the intervals shorter than 10 seconds) adjust the day and time of restoring the automatic (programmed) operation. In this example it could be Sunday, 2:00 p.m.
It means that the controller should resume its automatic operation 6 hours prior to our planned arrival and temperature of the rooms should grow accordingly.



Note

1. The automatic operation may be resumed anytime by pressing **AUTO**.
2. The required time advance of restoring the automatic operation strongly depends on specific properties of the object, its insulation, the type of heating and previous reduction of the temperature. The time advance should be selected experimentally.

7. Antifreeze mode

This operation mode results in maintaining the room temperature amounting to 5°C.

1. Move the battery cover to the right.
2. Move the slider to 5°C.

This function switched on introduces no changes in program settings, it only deactivates them. Once the buttons   **AUTO MAN PROG** are pressed an **OFF** indication appears at the display, giving evidence of deactivation of these functions.

Automatic operation may be restored any time by changing the slider to **HEAT**.

8. Switching the heating device off

1. Move the battery cover to the right.
2. Move the slider to **OFF**.

In this mode the heating device shall not switch on, irrespective of the time and temperature.

9. Working time meter of the heating device

The heating device while heating the rooms does not operate continuously. It means that the delivery of energy is interrupted.

In some cases the information of total number of operation hours of the heating device e.g. within a week or month would be very helpful.

AURATON 2020 and **AURATON 2020 TX RX Plus** are provided with a heating time meter, showing integer number of heating hours (the indicator '3' is then lit at the display).

In order to use the function the meter should be previously reset.

1. Move the battery cover to the right.
2. Press the **FILTER** button for at least 3 seconds, until the meter displays 000. Record or remember the day of the meter resetting.

After a certain time, for example one or several days, a week, or a month, shortly press the **FILTER** button again. The display will then show an integer number of the hours during which the heating was switched on (since the last reset). Comparison of the heating duration with total time elapsed since the reset allows for determining the ratio of real heating to idle time of the heating device.

Maximal number of accounted hours amounts to 999. When the time measured exceeds 250 hours a **FILTER** indication starts blinking, thus reminding of the need to check or reset the meter.



Once the meter achieves 999 hours it stops at this value until resetting. The heating time may be checked any time, similarly, the **FILTER** meter may be in any time reset.

Note: Is the heating operation time useless for the user, simply ignore the **FILTER** button and indication at the display.

They do not affect the operation of the **AURATON 2020** and **AURATON 2020 TX RX Plus** controllers.

10. Controller sensitivity (hysteresis)

Sensitivity of the **AURATON 2020** and **AURATON 2020 TX RX Plus** controllers may be adjusted to 3 available levels: 0.5°C (± 0.25), 1°C (± 0.5), 2°C (± 1). In the factory the sensitivity level is set to 1°C. It means that for the controller adjusted to 21°C it switches the heating device on for 20.5°C and switches it off for 21.5°C. Should it be changed, proceed as follows:

1. Press the **RETURN** button and keeping it simultaneously press **PROG**. The display shows the indication SPA instead of the time, and current sensitivity, e.g. 1°C, instead of the temperature.
2. Using the   buttons adjust the required sensitivity, from 0.5°C to 2°C.
3. Press **RETURN** or wait 10 seconds until normal operation mode of the controller will be resumed.

11. Installation

AURATON 2020 TX RX Plus

Auraton 2020 TX is a wireless controller. It means that it (**TX** - transmitter) communicates with heating device through receiver (**RX** - receiver) by radio waves. Installation is limited to connection of receiver with controlled device only.

The only installation operation includes connection of the **AURATON 2020 RX Plus** receiver to the executing device (e.g. a furnace).

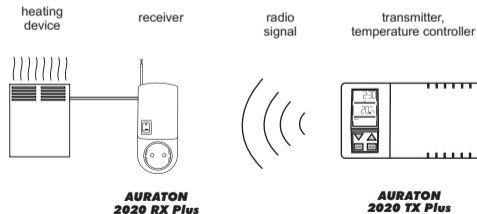

11.1 Cable connection to **AURATON 2020 RX Plus**

Note: During installation of the **RX** controller the power supply should be switched off.

It is recommended to charge a specialist company with the RX installation.

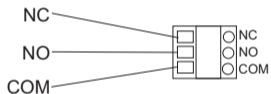

The cable terminals are located at the rear **RX** controller wall.

There are three terminals, marked by COM, NO, and NC. This is a typical unipolar two-state relay. In most cases the NC terminal remains unused.

12. Acquaintance with the **AURATON 2020 RX Plus**

12.1 Outer view

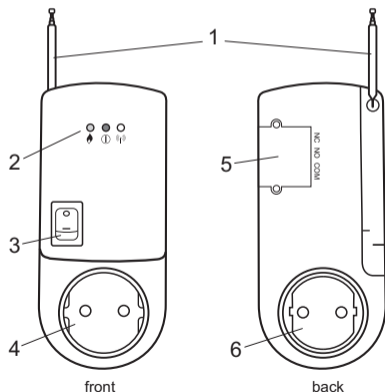

1. An extensible antenna – for communication with the **AURATON 2020 RX Plus** controller.
2. Control diodes
 - the green diode – informs that the executing device (e.g. a furnace) is operative.
 - the red diode – informs whether the **AURATON 2020 RX Plus** controller is supplied
 - the yellow diode – indicates the radio connection with temperature controller of **AURATON 2020 RX Plus**
3. The switch of the additional socket.
4. The additional socket – designed for connecting any equipment supplied from power network.
Note: max 5A.
5. Cover of the connector
6. Supplying plug.

13. Putting the **AURATON 2020 TX RX Plus** controller into operation for the first time

1. Put new alkaline batteries to the **AURATON 2020 RX Plus** controller.
2. Connect the **AURATON 2020 RX Plus** controller to the network socket and wait about 10 minutes in order to achieve the full receiver coverage.
3. The yellow diode " ⓘ " is lit - the receiver is accessed by the transmitter. The process is repeated each minute and lasts about 1 second. No diode signal or blinking diode indicates insufficient coverage.

Note: Coverage of the device is strongly affected by the materials used for construction of the building. In an open area the **AURATON 2020 TX Plus** connected with the **AURATON 2020 RX Plus** receiver should cover the distance up to 100m.

In buildings the coverage should reach 30m which is equivalent to penetration through several stories. In ferroconcrete structures the signal is strongly damped resulting in reduced coverage of the equipment.

Note: The **AURATON 2020 TX RX Plus** kit is set to the "085" communication code, being ready for operation upon the first installation. Nevertheless, in case of any communication problems between the **TX** controller and **RX** receiver refer to Section 11 – Setting a new communication code.

4. The red diode " ⓘ " lit indicates proper connection of the **AURATON 2020 RX Plus** receiver to 230V network.
5. The green diode " ⓘ " it indicates that the executive device (e.g. a furnace) is operative.

14. Protection

1. Should any transmission disturbance due, for example, to a strong electromagnetic impulse or voltage drop of **AURATON 2020 TX Plus** battery, prevent the **AURATON 2020 RX Plus** receiver from confirming the ON or OFF switching within 5 consecutive cycles (i.e. 5 minutes) the heating device switches off. This is to avoid overheating of the device. After elimination of the reason of such a disturbance the controller resumes its normal operation. Only in case of battery replacement reprogramming of **AURATON 2020 TX Plus** may be required, should the operation last longer than 30 seconds.
2. The signal transmitted to **AURATON 2020 RX Plus** is of digital encoded type. It means that several **AURATON 2020 TX Plus** controllers may operate in a small area without mutual interference.
In case of any doubts please contact the dealer or manufacturer.

15. Operation of **AURATON 2020 TX RX Plus**

As the transmission undergoes only in one direction the **AURATON 2020 TX Plus** emits, for security purposes, a short encoded signal every minute with a view to confirming the required state of the **AURATON 2020 RX Plus** receiver. This time interval is permanently set for the microprocessor, no change is possible.

Note: The controller may cooperate with an electric, gas, or oil device of the power exceeding load capacity of the terminals only through an intermediate switch of the power and operation suitable for the end device. In such a case please consult the dealer or guarantor.

Note: Avoid high induction and capacity loads as they result in burning the transmitter contacts out.

Note: The yellow control light of the receiver confirms transmitter signal reception. It is lit for one second every minute. The reasons of missing signal may be as follows:

1. **Excessive distance between transmitter and receiver (reduce the distance).**
2. **Replace used batteries of *AURATON 2020 TX Plus* with new alkaline ones. In some cases the batteries should be replaced in spite that the low battery indicator is not yet lit.**

The green diode signalizes switching the boiler (or another device) on.

16. Communication problems. Setting a new communication code

AURATON 2020 TX RX Plus allows for independent change of the communication protection code. The controller is set in the factory to the "085" code. Nevertheless, should any communication problem arise or another wireless kit operates in the proximity, the code should be changed according to the following instruction:

1. Disconnect the **AURATON 2020 RX Plus** receiver from the power socket for at least 5 seconds and, afterwards, connect it back again.
2. Press simultaneously the **RETURN** and **MAN** pushbuttons of **AURATON 2020 TX Plus**. The display shows the "085" code number adjusted in the factory.

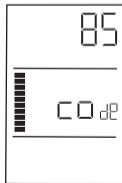

- Using the ▼ ▲ pushbuttons set a new communication code in the range from 1 to 255 and acknowledge it by pressing **RETURN**.
- The yellow diode "Ⓜ" of the **AURATON 2020 RX Plus** receiver should blink several times which means that the new code is recorded.
- If the changed code gives no improvement of the communication between the **AURATON 2020 TX Plus** controller and **AURATON 2020 RX Plus** receiver the code should be changed again.

17. Support of the **AURATON 2020 TX Plus** controller

The set includes a plastic support of the **AURATON 2020 TX Plus** controller.

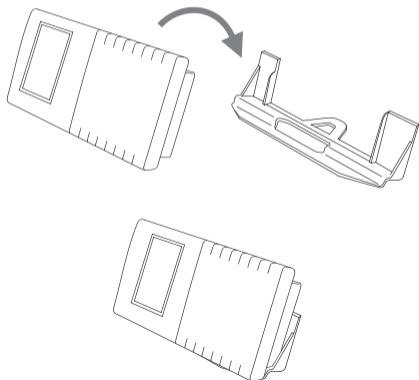

18. Connection diagrams

18.1 Diagram of direct **AURATON 2020** connection to a heating device.

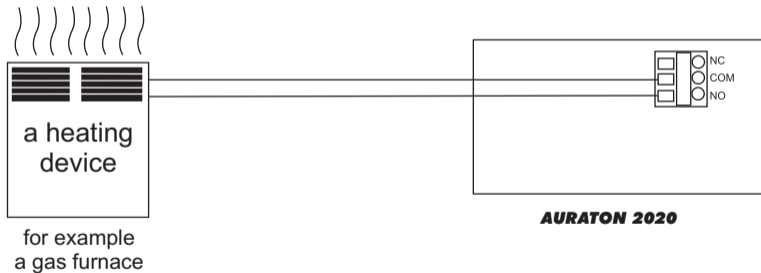

18.2 Diagram of direct connection of **AURATON 2020 P** provided with a floor sensor

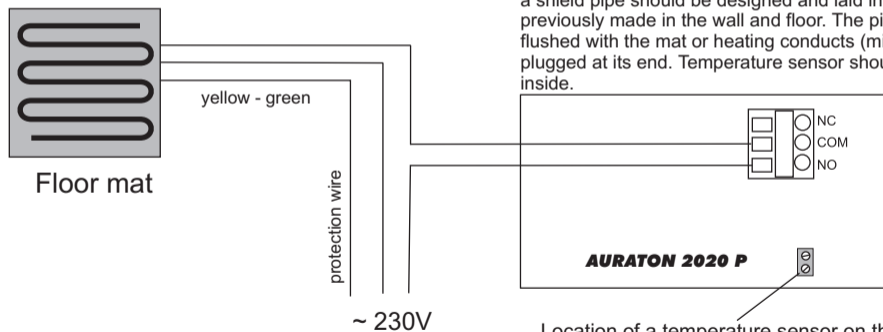

Note:

In case of the use of a controller provided with a floor sensor (i.e. **AURATON 2020 P**) the following operations should be made:

a branch box provided with a connector cube should be installed about 30cm above the floor level;

a shield pipe should be designed and laid in the hollow previously made in the wall and floor. The pipe should be flushed with the mat or heating conducts (min 50 cm) and plugged at its end. Temperature sensor should be located inside.

Location of a temperature sensor on the conduct (the option with floor heating)

18.3 Diagram of direct **AURATON 2020** connection to an electric device of the power below 230V and 5A

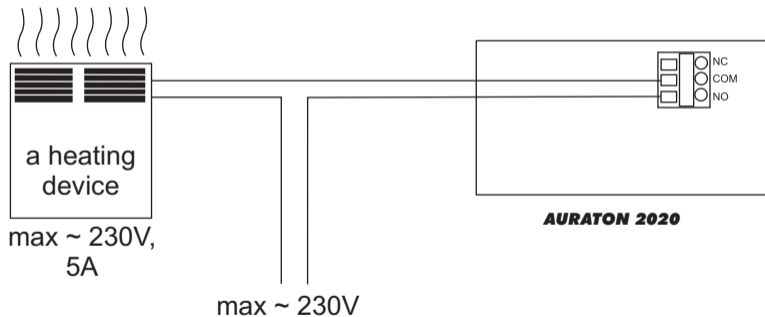

18.4 Diagram of direct **AURATON 2020** connection to a gas boiler independent on power supply, without the circulation pump

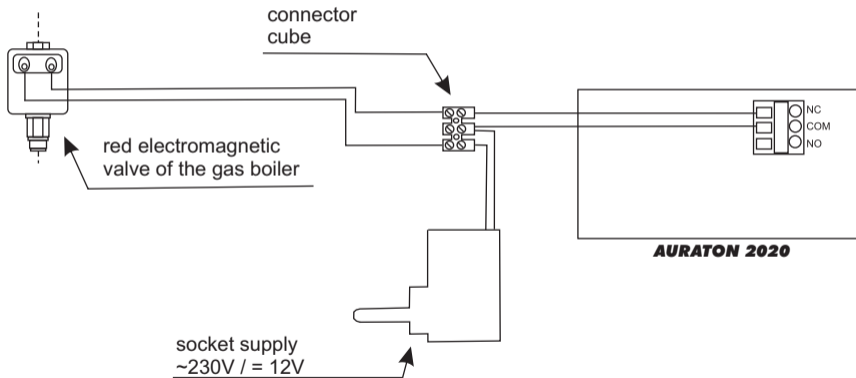

18.5 Diagram of direct **AURATON 2020 RX Plus** connection to a heating device

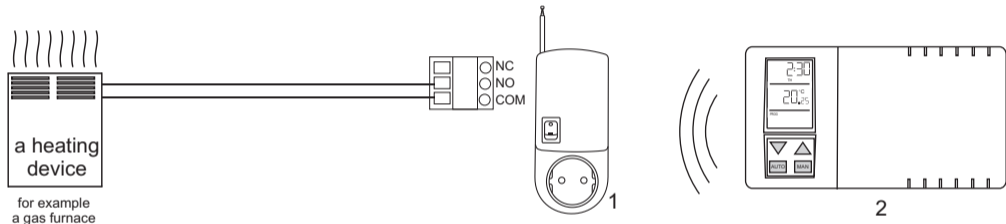

1. **AURATON 2020 RX Plus** (receiver).
2. **AURATON 2020 TX Plus** located in any room.

Note: In case of most of the heating device the short-circuit connector of the connection cube should be removed and replaced with the receiver wires.

In case of any doubts please contact the dealer or manufacturer.

(*) Note:

The controller may cooperate with an electric, gas, or oil device of the power exceeding load capacity of the terminals only through an intermediate switch of the power and operation suitable for the end device. In such a case please consult the dealer or guarantor.

Specialist data:

The executing relay.

It is a two-state self-sustaining relay with. For the standard setting of the micro-switch slider (slider 1 – bottom position) it has the following states:

1. for active switching indicator (No 7 of the display)
NO-COM short-circuited
COM-NC open
2. for inoperative switching indicator
NO-COM open
COM-NC short-circuited

Note:

Avoid high inductive and capacitance loads that are conducive to burning of the relay terminals.

19. Technical specification

1. The range of temperature measurement
0÷40°C (graduation 0.25°C)
2. The range of temperature control
5÷27°C (graduation 0.25°C)
3. Accuracy of indication
+/-1°C
4. Accuracy of the clock
± 70 seconds/per month
5. Programs
4 on working days, 2 on Saturday, 2 on Sunday
6. Sensitivity of temperature control
0.5°C, 1°C, or 2°C
(adjusted in the factory to 1°C)
7. Control mode
Heating
8. Admissible load of the terminals (*)
230V AC, 50Hz, 5A
9. Supply
2 R6 batteries, alkaline ones for the TX version
10. Dimensions
154´80´30mm (width´height´thickness)
11. Operating temperature
from 0 to 50°C
12. Storage temperature
from -20 to 50°C
14. Humidity conditions
from 5 to 90%